

Name: _____
 Date: _____
 Track: _____

Track Conditions
 Size: Open Med. Tight
 Traction: High Med. Low
 Surface: Smooth Med. Bumpy

Result
 Race Time / Lap: _____
 Best Lap (1Lap): _____

Front Suspension

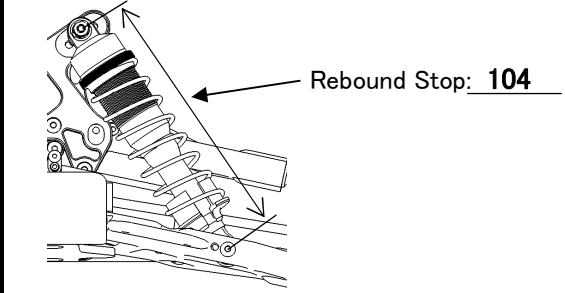

Tension Rod: E2107A(Long)
 E2107B(Short)

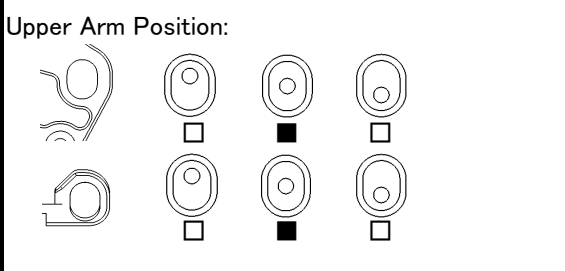

Ride Height: _____
 Toe Angle: _____ **out 1°**
 Kingpin Ball Spacer: _____ **1**
 Wheel Hub: _____ **E0239(0)**
 Anti Roll Bar: _____ **φ 2.4**
 Upper Arm Spacer: _____ **2**

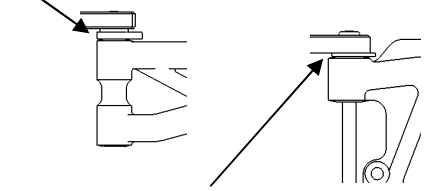

Lower Arm Spacer: _____ **0**

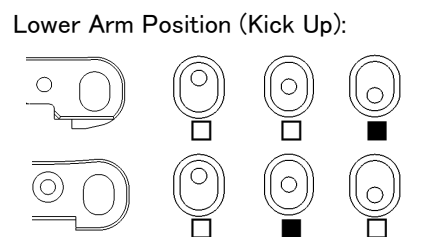

Front Shocks

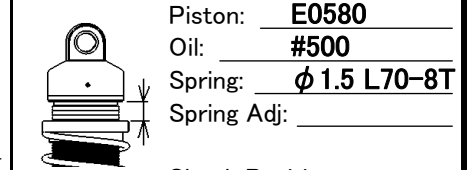

Piston: _____ **E0580**
 Oil: _____ **#500**
 Spring: _____ **φ 1.5 L70-8T**
 Spring Adj: _____

Shock Position:

Pivot Ball Position: Front Rear
 Damper Stay: E2502(Aluminum)
 E2511(CFRP)

Steering Ackerman

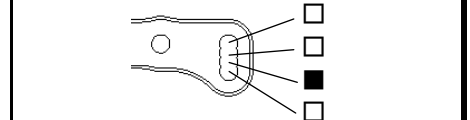

Rear Suspension

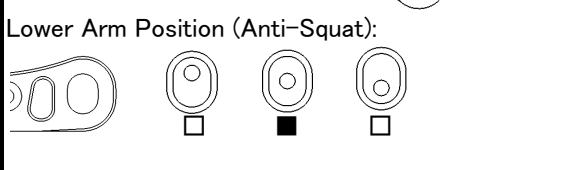
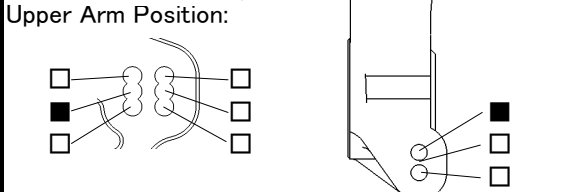
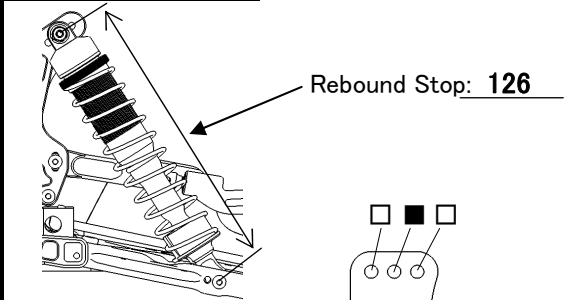

Ride Height: _____
 Camber Angle: _____ **-2.5°**
 Wheel Hub: _____ **E0239(0)**
 Anti Roll Bar: _____ **φ 2.9**
 Lower Arm Spacer: _____ **0**

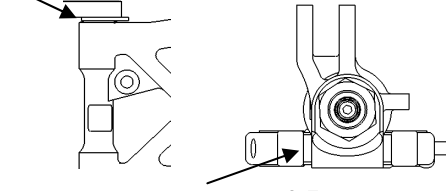

Upright Spacer: _____ **2.5**

Upright: E2106-B
 E2118(Aluminum)

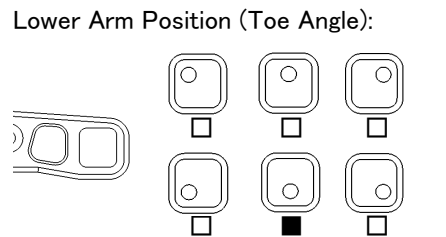

Rear Shocks

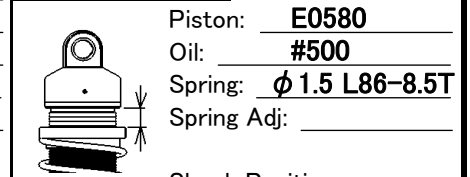

Piston: _____ **E0580**
 Oil: _____ **#500**
 Spring: _____ **φ 1.5 L86-8.5T**
 Spring Adj: _____

Shock Position:

Pivot Ball Position: Front Rear
 Damper Stay: E2503(Aluminum)
 E2514(CFRP)

Engine

Type: _____ Plug: _____
 Gasket: _____ Reducer: _____
 Muffler: _____ Fuel: _____
 Engine Mount: E0701(Standard) E0703(One Piece)

Diff. Oil

Front: _____ **#7000** O-Ring: _____ pcs.
 Center: _____ **#7000** _____ pcs.
 Rear: _____ **#3000** _____ pcs.

Tires

	Front	Rear
Type:	_____	_____
Compound:	_____	_____
Inserts:	_____	_____
Wheel:	_____	_____

Clutch

Clutch Bell: _____ **13T** Spur Gear: _____ **46T**
 Clutch Shoes: _____ **E0710**
 Clutch Spring: _____ **φ 1.0**

Body/Wing

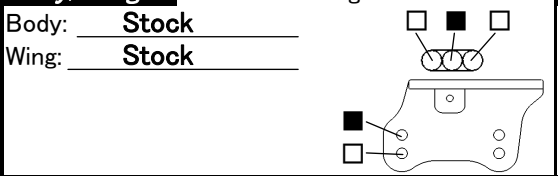

Comments

.....

